

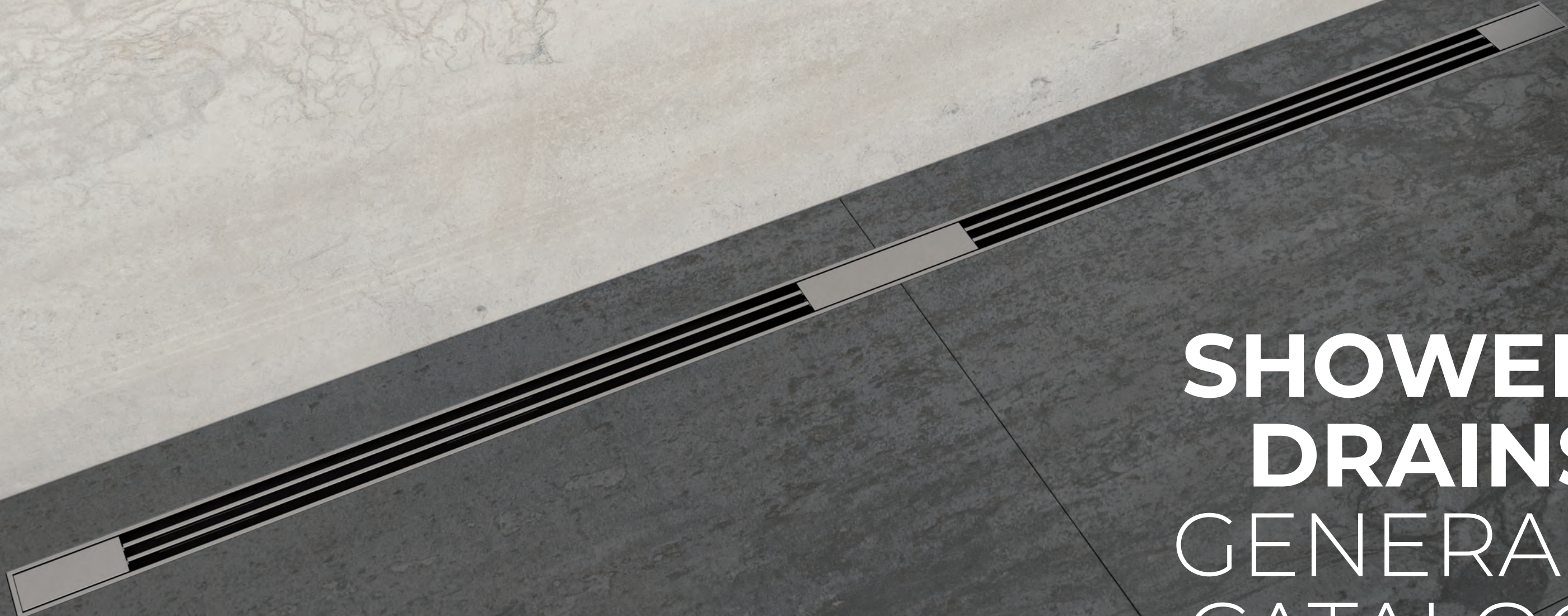

Next level  
bathroom  
business  
solutions



# SHOWER DRAINS GENERAL CATALOG



# About us

With a new and dynamic era coming, we decided to create something new and refreshing in the sanitary industry. We all thrive for personal and business efficiency so WEBE company is our effort to show to the world ourselves at our best.

We are focused on the production of linear shower drains where we have a huge variety of models suitable for both technically and design-wise most demanding requests.

With more than 10 years in the bathroom industry focusing on shower drain production, we bring value to our clients by implementing our advanced R&D and design expertise in creating new and exciting products for the global market.

Our key strength is knowledge and flexibility. We are focused on bringing value for all our partners and consumers with a specific approach to every market's needs and preferences.



# Contents

- 4** Manufacturing technology
- 6** Double drainage system
- 8** Refreshing design
- 9** Easy installation and maintenance
- 10** WEBE DRAIN MODEL 1
- 14** WEBE DRAIN MODEL 2
- 18** WEBE DRAIN MODEL 3
- 22** WEBE DRAIN MODEL 4
- 26** WEBE DRAIN MODEL 5
- 30** WEBE DRAIN MODEL 6
- 34** WEBE DRAIN MODEL 7
- 38** WEDI – Next level bathroom business solutions

# Manufacturing technology

Based on 10 years of experience in the shower drains industry worldwide and 2 years of R&D process we have decided to use the following technologies which give us solid ground for worldwide positioning.

## Injection molding

Injection molding of plastic with high-quality modular molds ensures that every piece is the same and gives us an opportunity to manufacture huge numbers of products from day one. Also plastic gives us flexibility in matter of shapes, plumbing connections, and sizes which was critical for our decision to manufacture our products from ABS and PP material.



## Ultrasonic welding

When we wanted to solve how to perfectly connect 2 pcs of plastic, ultrasonic welding came as the most reliable and clean solution to do the job. This was one of the most important technical tasks for us so we decided to use the best machines in the business to get 100% technically and aesthetically accurate welding surface.



## Laser technology

For our metal parts we have decided to use only laser technology for all our processes of cutting, welding, and engravings on our products' stainless steel parts. Although this technology is more expensive compared to traditional metal shaping technologies it allows us to have the perfect final touch on the product and high manufacturing capability.

## Blister vacuum forming

We have been following the needs of our clients, especially from Hardware shops and the DIY sector so we have decided to invest also in a Vacuum Forming Machine where now we have the capability to put all of our products inside of transparent PET blisters no matter the size, shape, or color of the product. Together with ultrasonic welding, it creates unlimited flexibility regarding packing and displaying our complete product portfolio.



# Double drainage system

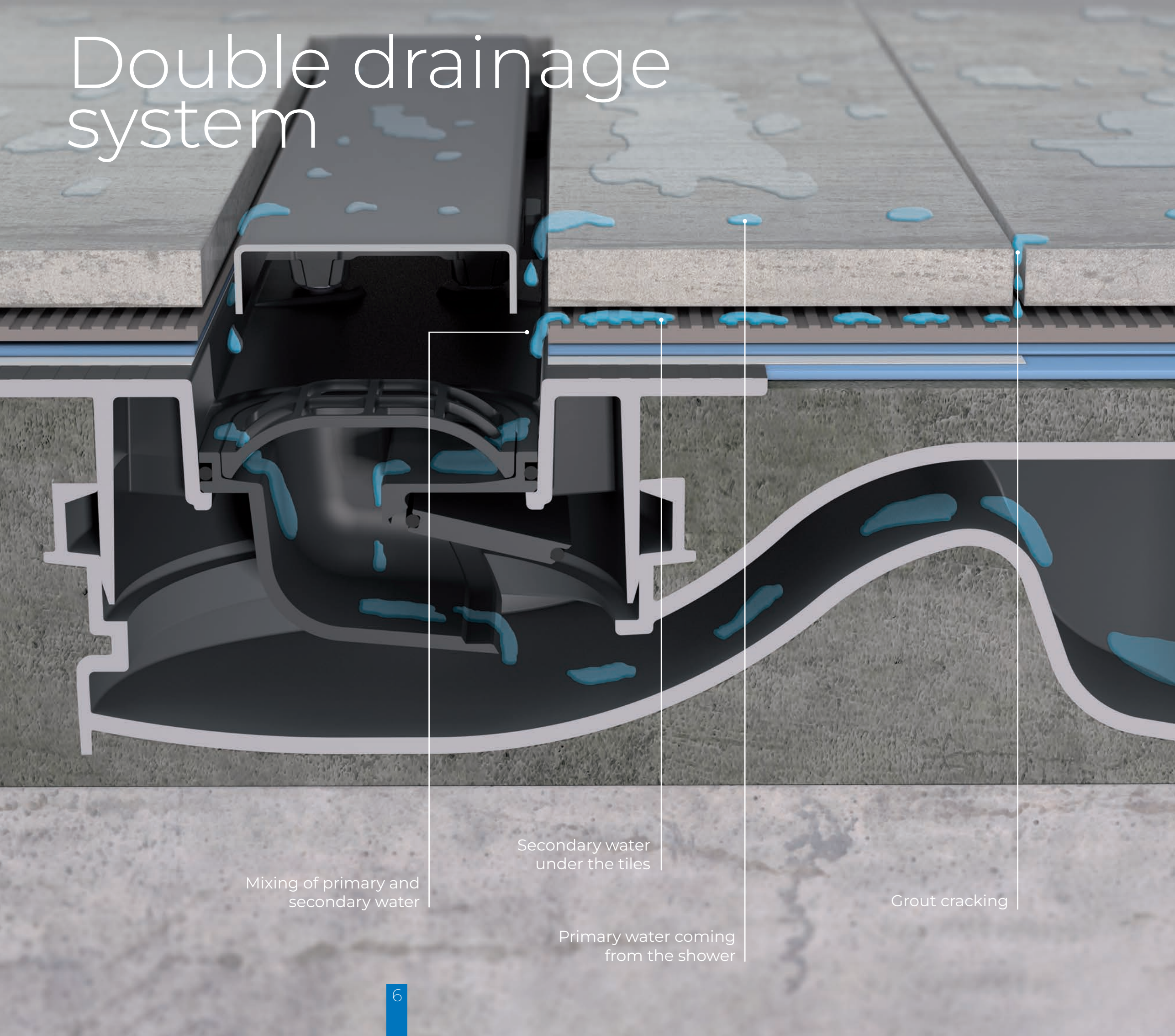

Mixing of primary and secondary water

Secondary water under the tiles

Primary water coming from the shower

Grout cracking

## High flow rate – two times less cleaning

Thanks to industrial design of our product every component and proper water routing we have succeed to reach high numbers of flow rate in every of our products comparing to competition which for all of our clients means two times less cleaning and maintenance.

## Double siphon system

We consider smell and insect protection in your bathroom very seriously so when designing our products we have decided that use two siphons instead of one. Every of our products have both water and dry siphon included which both significantly slows down evaporation of water from siphon and close down sewage once water is gone out completely from the system. This solution give us possibility of having very low installation height product with maximally safe smell protection solution especially in situations like bathrooms in weekend houses and with underfloor heating.

## Double drainage system

We offer a unique option to apply double drainage in a barrier-free installation. This way, any water leaking under the tiles due to porous sealant or cracks can flow back into the shower drain. Double drainage only applies when the entire wet area is sealed with a certified waterproofing membrane.

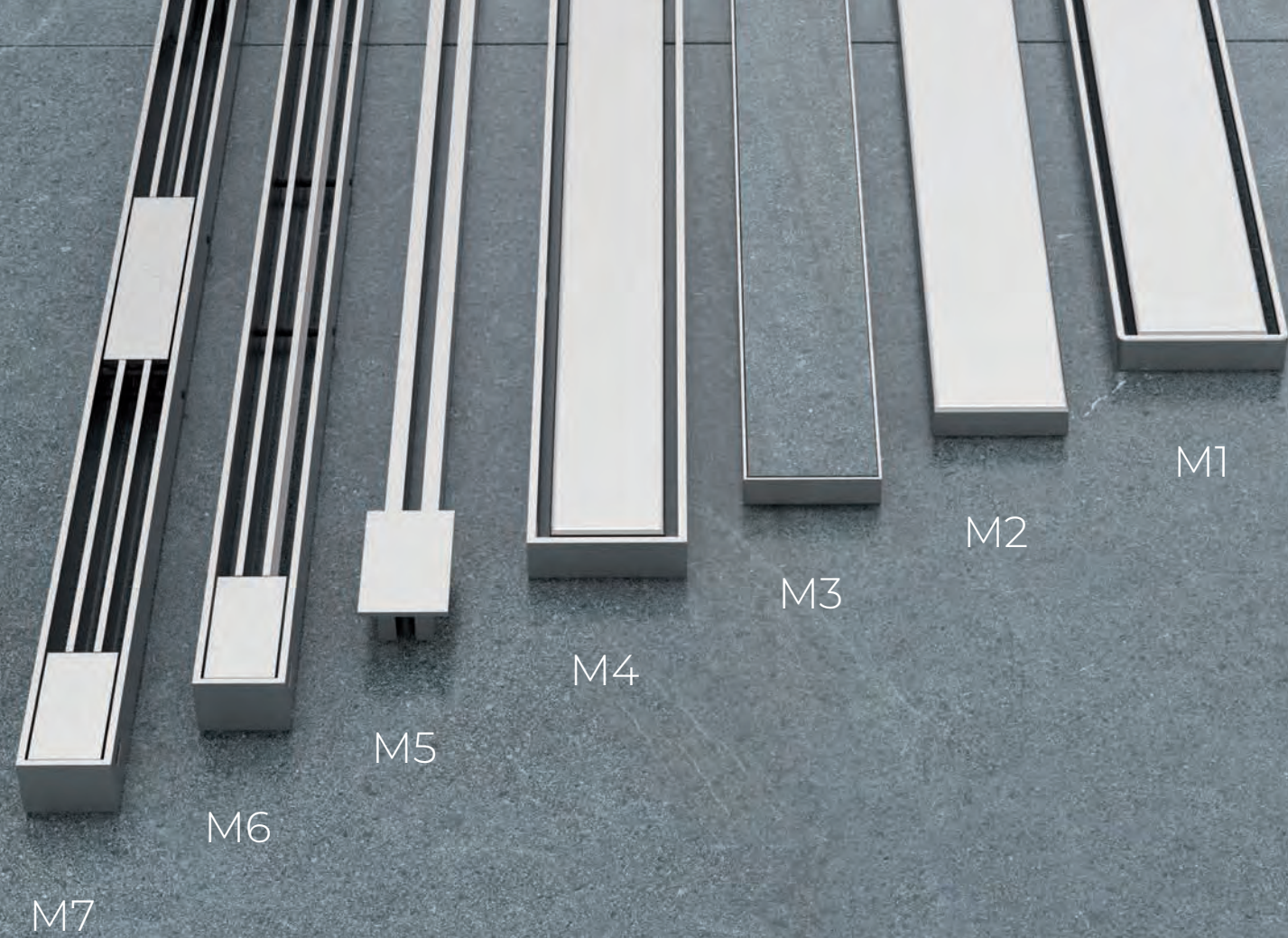

# Refreshing design

We offer a huge variety of different grid designs which both technically and design wise fit all of our client needs. Our models also implemented two in one reversible grating system so you can change the design of your bathroom as it suits you.

# Easy installation and maintenance

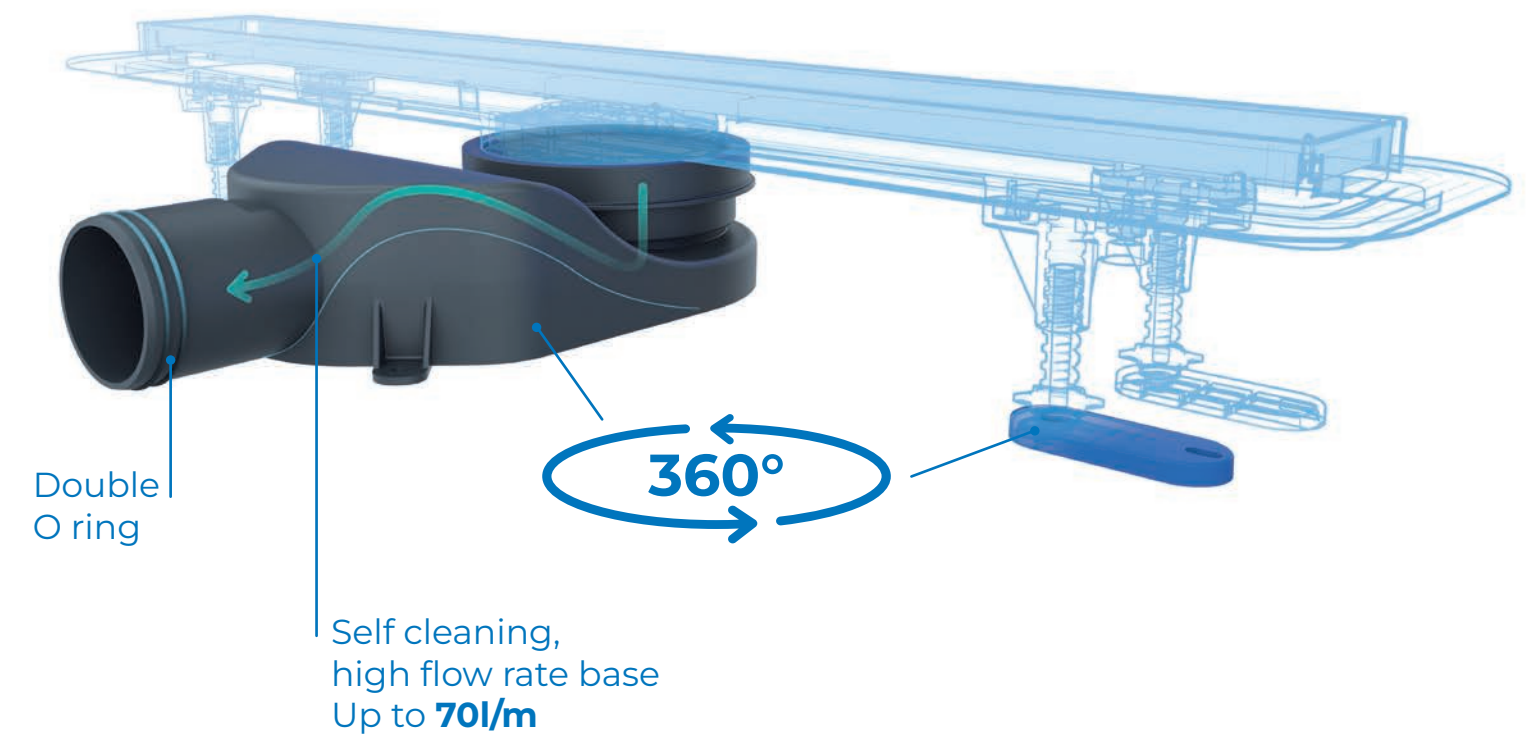

When we were thinking about professional's and end users we have decided to use basic fundamentals in engineering and to create product which you can assemble in under one minute and which have high flow rate and self-cleaning siphon. This properties give unique value to everybody who is using our products and they are represented in every of our models.



# WEBE DRAIN MODEL 1



## WEBE DRAIN MODEL 1 Main advantages

- Flow rate **70 l/min** , **48l/min** (double siphon)
- **Double siphon** . Dry and water combined.
- **58 mm** installation height
- Two in one **reversible grating**
- **Easy** installation and maintenance

PRODUCT NAME	WEBE DRAIN MODEL 1 600	WEBE DRAIN MODEL 1 700	WEBE DRAIN MODEL 1 800	WEBE DRAIN MODEL 1 900	WEBE DRAIN MODEL 1 1000
Dimensions	600 mm	700 mm	800 mm	900 mm	1000 mm
PRODUCT CODE	WDM1600	WDM1700	WDM1800	WDM1900	WDM11000

# WEBE DRAIN **MODEL 1**



**HIGH FLOW RATE OF  
70 L/MIN**

2 TIMES LESS CLEANING.

**DOUBLE SIPHON,  
DOUBLE PROTECTION.**

WATER & DRY SIPHON COMBINED  
IN ONE PRODUCT.

**ONLY 58mm  
INSTALLATION HEIGHT**

PERFECT SOLUTION FOR ALL  
RENOVATION PROJECTS.

**TWO IN ONE  
REVERSABLE GRATING**

FLEXIBLE STAINLESS STEEL AND  
CERAMIC FINISH IN THE SAME  
PRODUCT.



# WEBE DRAIN MODEL 2



## WEBE DRAIN MODEL 2 Main advantages

- Flow rate **66 l/min** , **48l/min** (double siphon)
- **Double siphon** . Dry and water combined.
- **65 mm** installation height
- Two in one **reversible grating**
- Double drainage system

PRODUCT NAME	WEBE DRAIN MODEL 2 600	WEBE DRAIN MODEL 2 700	WEBE DRAIN MODEL 2 800	WEBE DRAIN MODEL 2 900	WEBE DRAIN MODEL 2 1000
Dimensions	600 mm	700 mm	800 mm	900 mm	1000 mm
PRODUCT CODE	WDM2600	WDM2700	WDM2800	WDM2900	WDM21000

## WEBE DRAIN **MODEL 2**



**HIGH FLOW RATE OF  
66 L/MIN**

2 TIMES LESS CLEANING.

**DOUBLE DRAINAGE  
SYSTEM**

**DOUBLE SIPHON,  
DOUBLE PROTECTION.**

WATER & DRY SIPHON COMBINED  
IN ONE PRODUCT.

**ONLY 65mm  
INSTALLATION HEIGHT**

PERFECT SOLUTION FOR ALL  
RENOVATION PROJECTS.

**TWO IN ONE  
REVERSABLE GRATING**

FLEXIBLE STAINLESS STEEL AND  
CERAMIC FINISH IN THE SAME  
PRODUCT.

# WEBE DRAIN MODEL 3

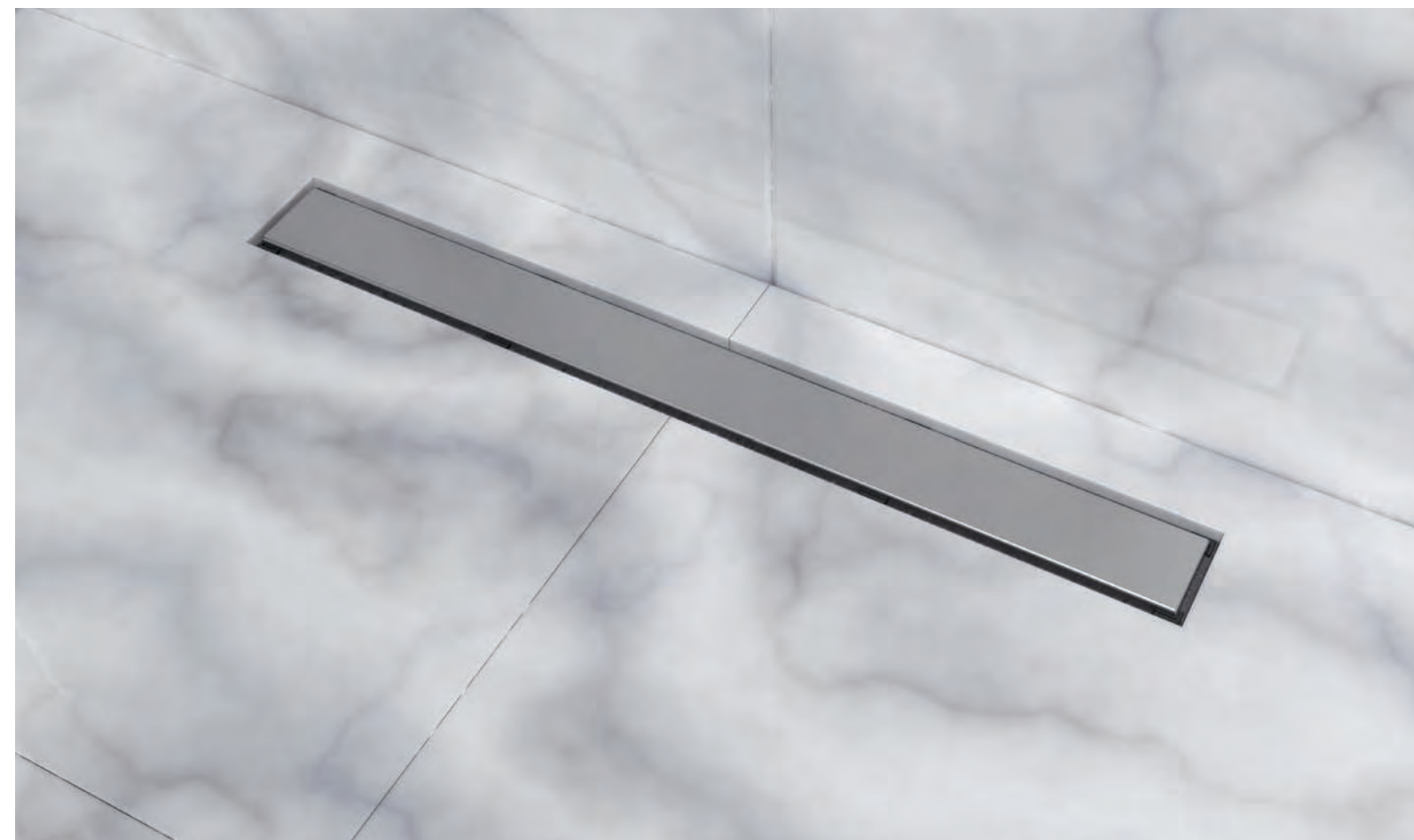

## WEBE DRAIN MODEL 3 Main advantages

- Flow rate **66 l/min** , **48l/min** (double siphon)
- **Double siphon** . Dry and water combined.
- **65 mm** installation height
- Two in one **reversible grating**
- Double drainage system
- Height adjustment of grid **+/- 12 mm**

PRODUCT NAME	WEBE DRAIN MODEL 3 600	WEBE DRAIN MODEL 3 700	WEBE DRAIN MODEL 3 800	WEBE DRAIN MODEL 3 900	WEBE DRAIN MODEL 3 1000
Dimensions	600 mm	700 mm	800 mm	900 mm	1000 mm
PRODUCT CODE	WDM3600	WDM3700	WDM3800	WDM3900	WDM31000

## WEBE DRAIN **MODEL 3**



**HIGH FLOW RATE OF  
66 L/MIN**

2 TIMES LESS CLEANING.

**DOUBLE DRAINAGE  
SYSTEM**

**DOUBLE SIPHON,  
DOUBLE PROTECTION.**

WATER & DRY SIPHON COMBINED  
IN ONE PRODUCT.

**ONLY 65mm  
INSTALLATION HEIGHT**

PERFECT SOLUTION FOR ALL  
RENOVATION PROJECTS.

**TWO IN ONE  
REVERSABLE GRATING**

FLEXIBLE STAINLESS STEEL AND  
CERAMIC FINISH IN THE SAME  
PRODUCT.

**HEIGHT ADJUSTMENT  
OF THE GRID**

MODEL HAS THE POSSIBILITY TO  
ADJUST TO ANY BATHROOM FLOOR  
THICKNESS.



# WEBE DRAIN MODEL 4



## WEBE DRAIN MODEL 4 Main advantages

- Flow rate **66 l/min** , **48l/min** (double siphon)
- **Double siphon** . Dry and water combined.
- **65 mm** installation height
- Two in one **reversible grating**
- Double drainage system
- Height adjustment of grid **+/- 12 mm**

PRODUCT NAME	WEBE DRAIN MODEL 4 600	WEBE DRAIN MODEL 4 700	WEBE DRAIN MODEL 4 800	WEBE DRAIN MODEL 4 900	WEBE DRAIN MODEL 4 1000
Dimensions	600 mm	700 mm	800 mm	900 mm	1000 mm
PRODUCT CODE	WDM4600	WDM4700	WDM4800	WDM4900	WDM41000

## WEBE DRAIN **MODEL 4**

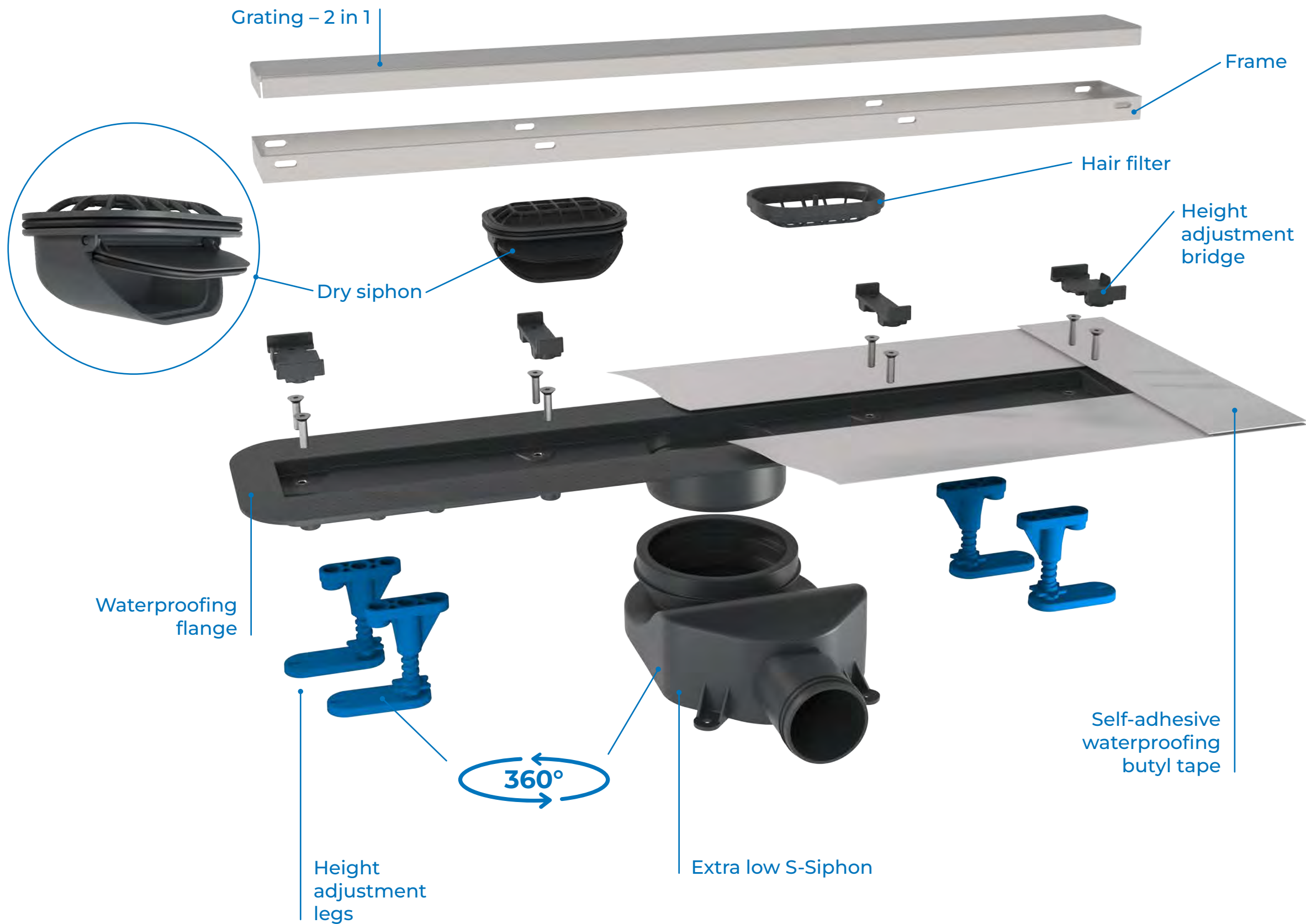

**HIGH FLOW RATE OF  
66 L/MIN**

2 TIMES LESS CLEANING.

**DOUBLE DRAINAGE  
SYSTEM**

**DOUBLE SIPHON,  
DOUBLE PROTECTION.**

WATER & DRY SIPHON COMBINED  
IN ONE PRODUCT.

**ONLY 65mm  
INSTALLATION HEIGHT**

PERFECT SOLUTION FOR ALL  
RENOVATION PROJECTS.

**TWO IN ONE  
REVERSABLE GRATING**

FLEXIBLE STAINLESS STEEL AND  
CERAMIC FINISH IN THE SAME  
PRODUCT.

**HEIGHT ADJUSTMENT  
OF THE GRID**

MODEL HAS THE POSSIBILITY TO  
ADJUST TO ANY BATHROOM FLOOR  
THICKNESS AND HAS AN INTEGRATED  
CERAMIC PROFILE.



# WEBE DRAIN MODEL 5

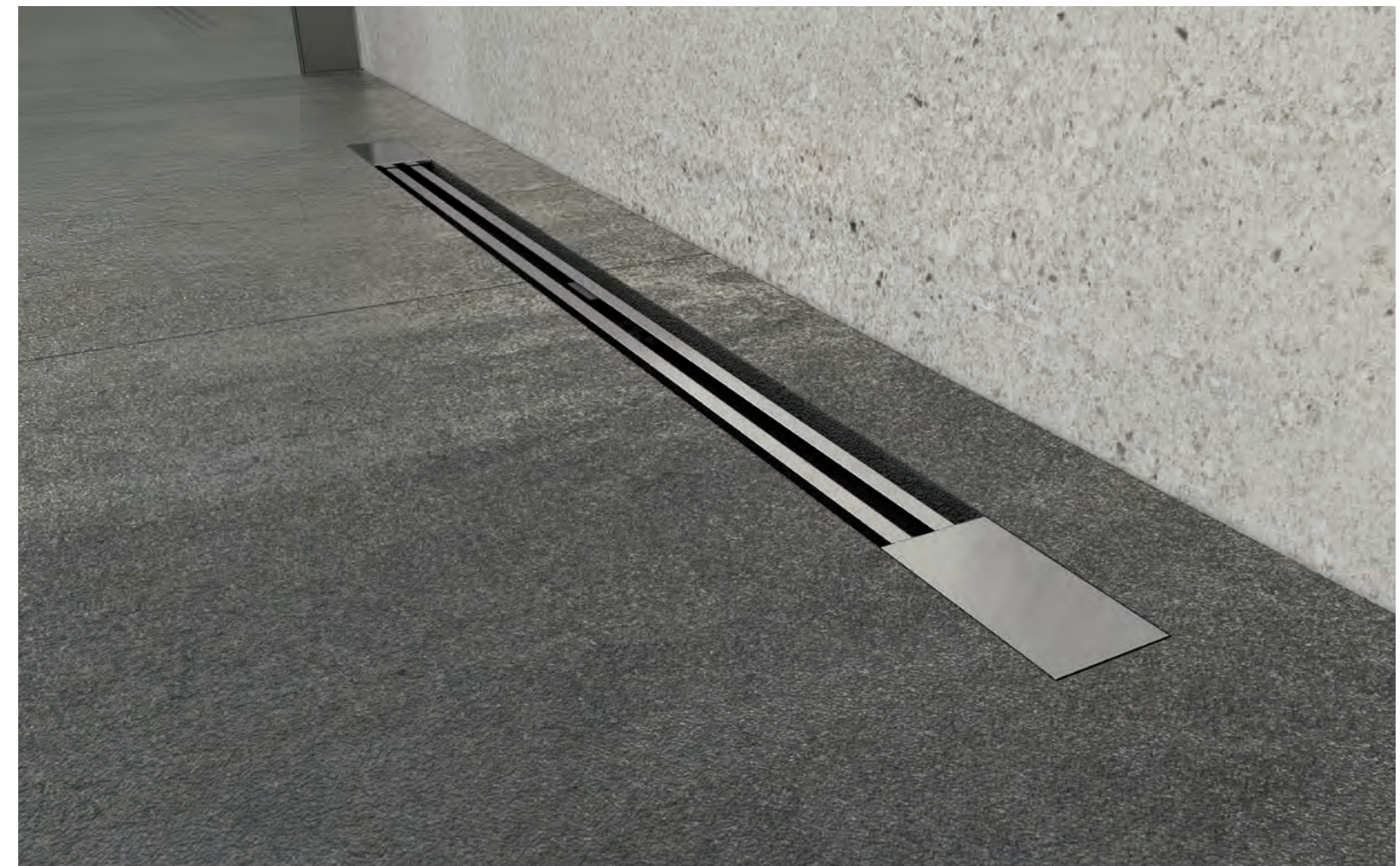

## WEBE DRAIN MODEL 5 Main advantages

- Flow rate **45 l/min** , **40l/min** (double siphon)
- **Double siphon** . Dry and water combined.
- **68 mm** installation height
- Double drainage system
- Height adjustment of grid **+/- 12 mm**

PRODUCT NAME	WEBE DRAIN MODEL 5 600	WEBE DRAIN MODEL 5 700	WEBE DRAIN MODEL 5 800	WEBE DRAIN MODEL 5 900	WEBE DRAIN MODEL 5 1000
Dimensions	600 mm	700 mm	800 mm	900 mm	1000 mm
PRODUCT CODE	WDM5600	WDM5700	WDM5800	WDM5900	WDM51000

## WEBE DRAIN **MODEL 5**

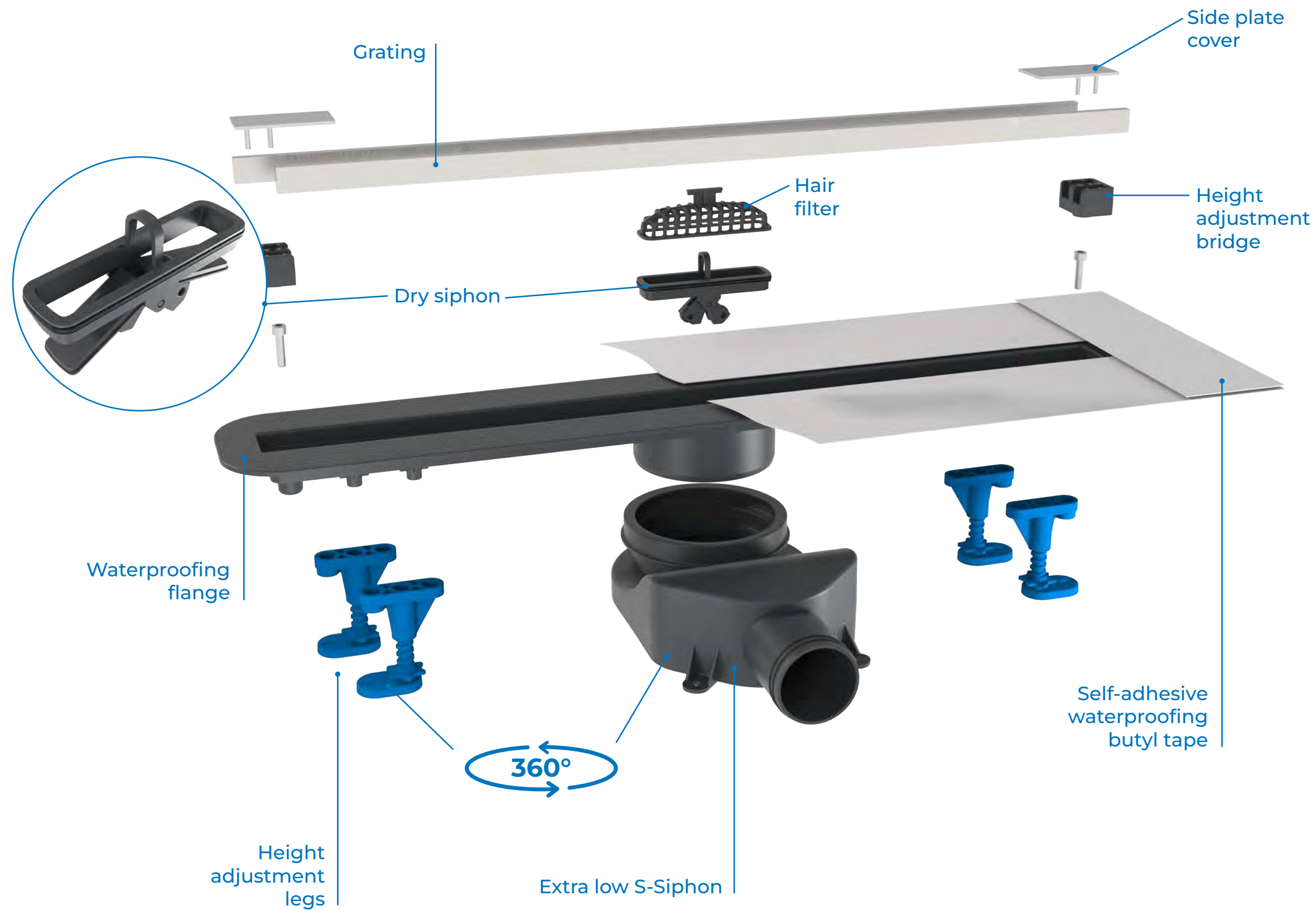

## DOUBLE DRAINAGE SYSTEM

### DOUBLE SIPHON, DOUBLE PROTECTION.

WATER & DRY SIPHON COMBINED IN ONE PRODUCT.

### ONLY 68mm INSTALLATION HEIGHT

PERFECT SOLUTION FOR ALL RENOVATION PROJECTS.

### SLIM MODEL

DESIGNER SOLUTION.

### HEIGHT ADJUSTMENT OF THE GRID

MODEL HAS THE POSSIBILITY TO ADJUST TO ANY BATHROOM FLOOR THICKNESS.



# WEBE DRAIN MODEL 6



## WEBE DRAIN MODEL 6 Main advantages

- Flow rate **45 l/min** , **40l/min** (double siphon)
- **Double siphon** . Dry and water combined.
- **68 mm** installation height
- Double drainage system
- Height adjustment of grid **+/- 12 mm**

PRODUCT NAME	WEBE DRAIN MODEL 6 600	WEBE DRAIN MODEL 6 700	WEBE DRAIN MODEL 6 800	WEBE DRAIN MODEL 6 900	WEBE DRAIN MODEL 6 1000
Dimensions	600 mm	700 mm	800 mm	900 mm	1000 mm
PRODUCT CODE	WDM6600	WDM6700	WDM6800	WDM6900	WDM61000

## WEBE DRAIN **MODEL 6**

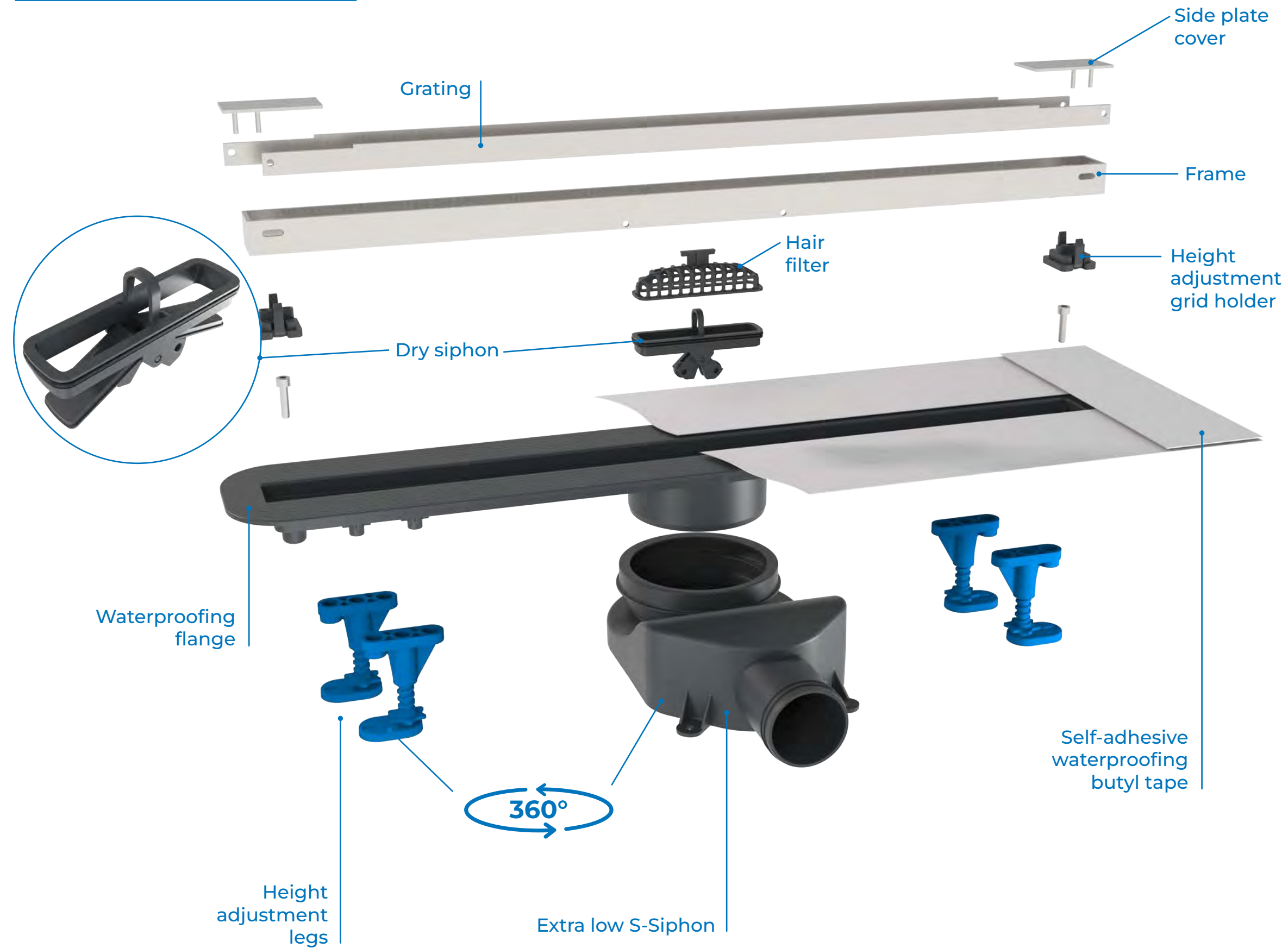

## DOUBLE DRAINAGE SYSTEM

### DOUBLE SIPHON, DOUBLE PROTECTION.

WATER & DRY SIPHON COMBINED IN ONE PRODUCT.

### ONLY 68mm INSTALLATION HEIGHT

PERFECT SOLUTION FOR ALL RENOVATION PROJECTS.

### SLIM MODEL

DESIGNER SOLUTION.

### HEIGHT ADJUSTMENT OF THE GRID

MODEL HAS THE POSSIBILITY TO ADJUST TO ANY BATHROOM FLOOR THICKNESS.

# WEBE DRAIN MODEL 7

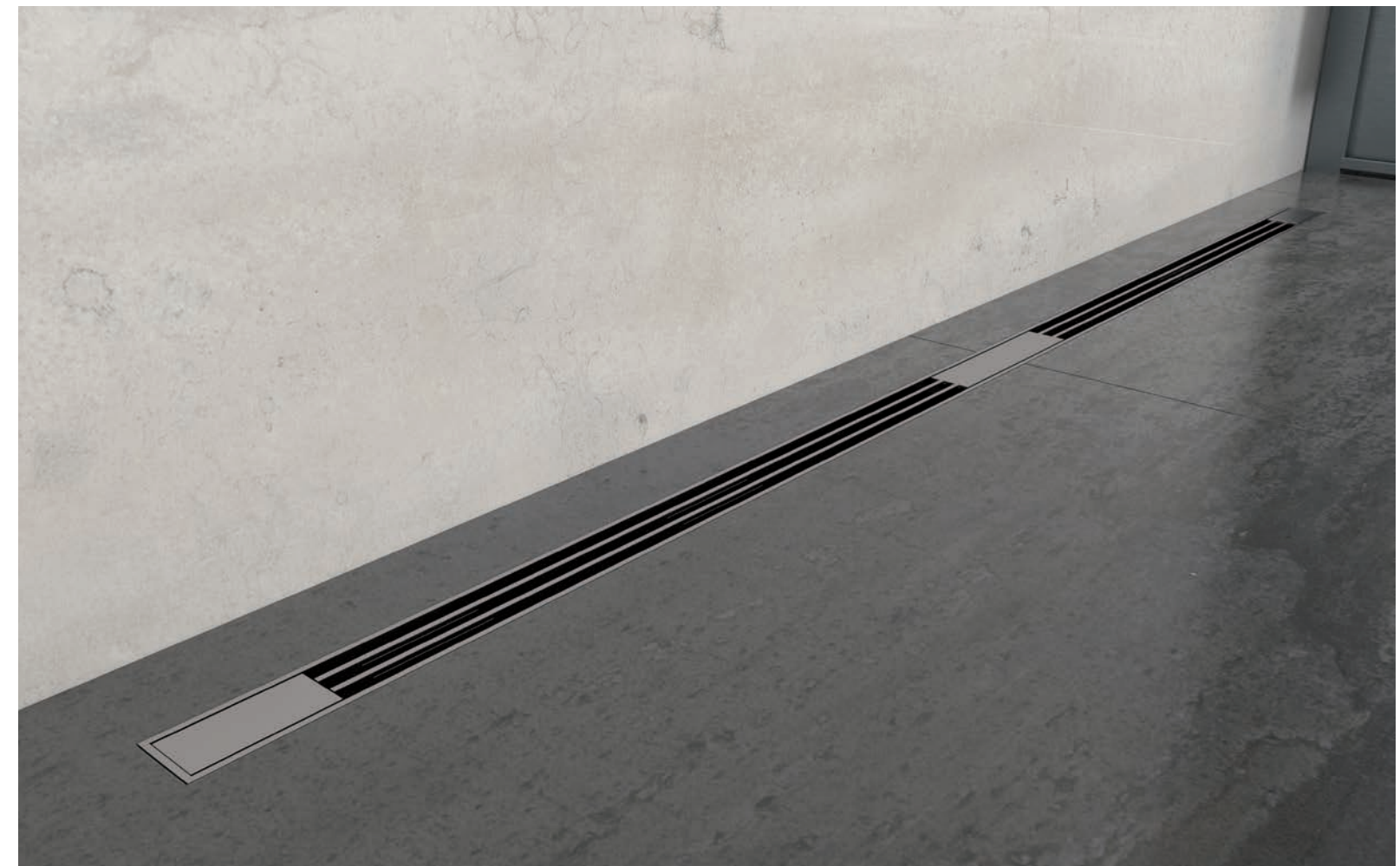

## WEBE DRAIN MODEL 7 Main advantages

- Flow rate **45 l/min** , **40l/min** (double siphon)
- **Double siphon** . Dry and water combined.
- **68 mm** installation height
- Double drainage system
- Height adjustment of grid **+/- 12 mm**

PRODUCT NAME	WEBE DRAIN MODEL 7 600	WEBE DRAIN MODEL 7 700	WEBE DRAIN MODEL 7 800	WEBE DRAIN MODEL 7 900	WEBE DRAIN MODEL 7 1000
Dimensions	600 mm	700 mm	800 mm	900 mm	1000 mm
PRODUCT CODE	WDM7600	WDM7700	WDM7800	WDM7900	WDM71000

# WEBE DRAIN **MODEL 7**

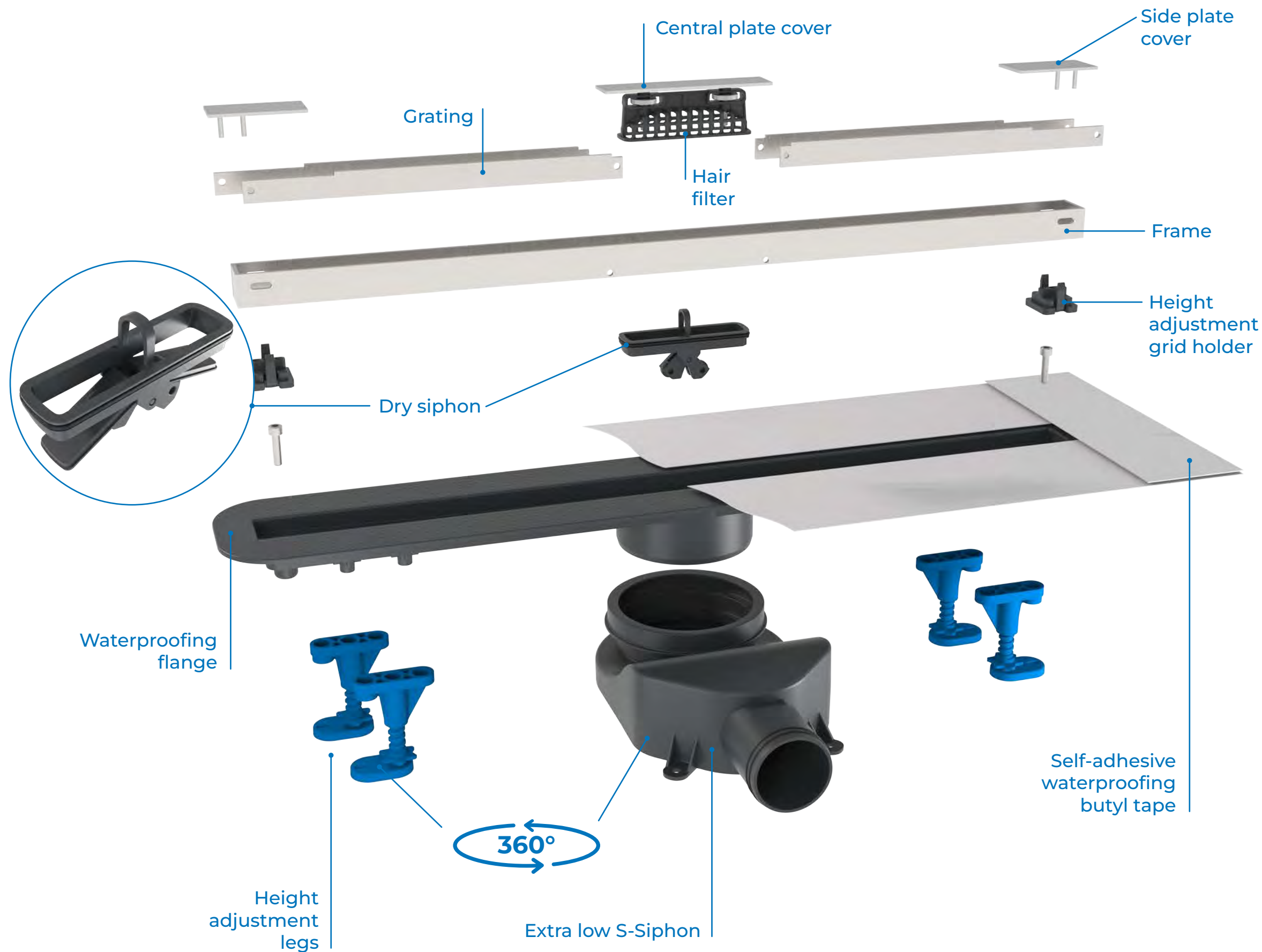

## DOUBLE DRAINAGE SYSTEM

### DOUBLE SIPHON, DOUBLE PROTECTION.

WATER & DRY SIPHON COMBINED IN ONE PRODUCT.

### ONLY 68mm INSTALLATION HEIGHT

PERFECT SOLUTION FOR ALL RENOVATION PROJECTS.

### SLIM MODEL

DESIGNER SOLUTION.

### HEIGHT ADJUSTMENT OF THE GRID

MODEL HAS THE POSSIBILITY TO ADJUST TO ANY BATHROOM FLOOR THICKNESS.

### EASY TO CLEAN

# WEBE – Next level bathroom business solutions



## BRANDING OF PRODUCTS – OEM SPECIALIST

When thinking about the business model we gonna use and which can maximize value for our factory, distributors, professionals, and end users in a short period of time we have decided to be somebody behind the curtain and maximally utilize ours and our partner's strengths. We are focused on product, production, and business development for specific product groups on a global level where we use our worldwide experience to create a tailor-made solution for each of our partners and specific market situations. Our partners use the power of their brand which they have developed and their experience in the sales and distribution of products in a specific market. In combination with these two strengths, we create and add value for our buyers, professionals and end users at a rapid pace.

## STRATEGIC POSITIONING , SALES AND MARKETING SUPORT

We offer our partners consultant services for the positioning of our products in specific markets based on our ten-year worldwide experience in marketing and sales of bathroom and plumbing products. We have successfully set up and implemented running businesses in more than 40 countries in Europe, Africa, the Middle East, and India so we have great knowledge of this specific product business development. Our team consists of Export managers, Product managers, Import-Export specialists, Graphic designers, and SEO and Social network managers who are there to support the shaping of our mutual business on the highest level.

## PACKING AND MARKING ON DEMAND

We offer a few options for packaging. Branded box, PET blister, and Branded bag with EUR slot and unlimited options for their design. We can also adjust master box packaging and labeling of products as per client's needs so our partners from the first moment have perfectly optimized solutions for the very beginning of our business.

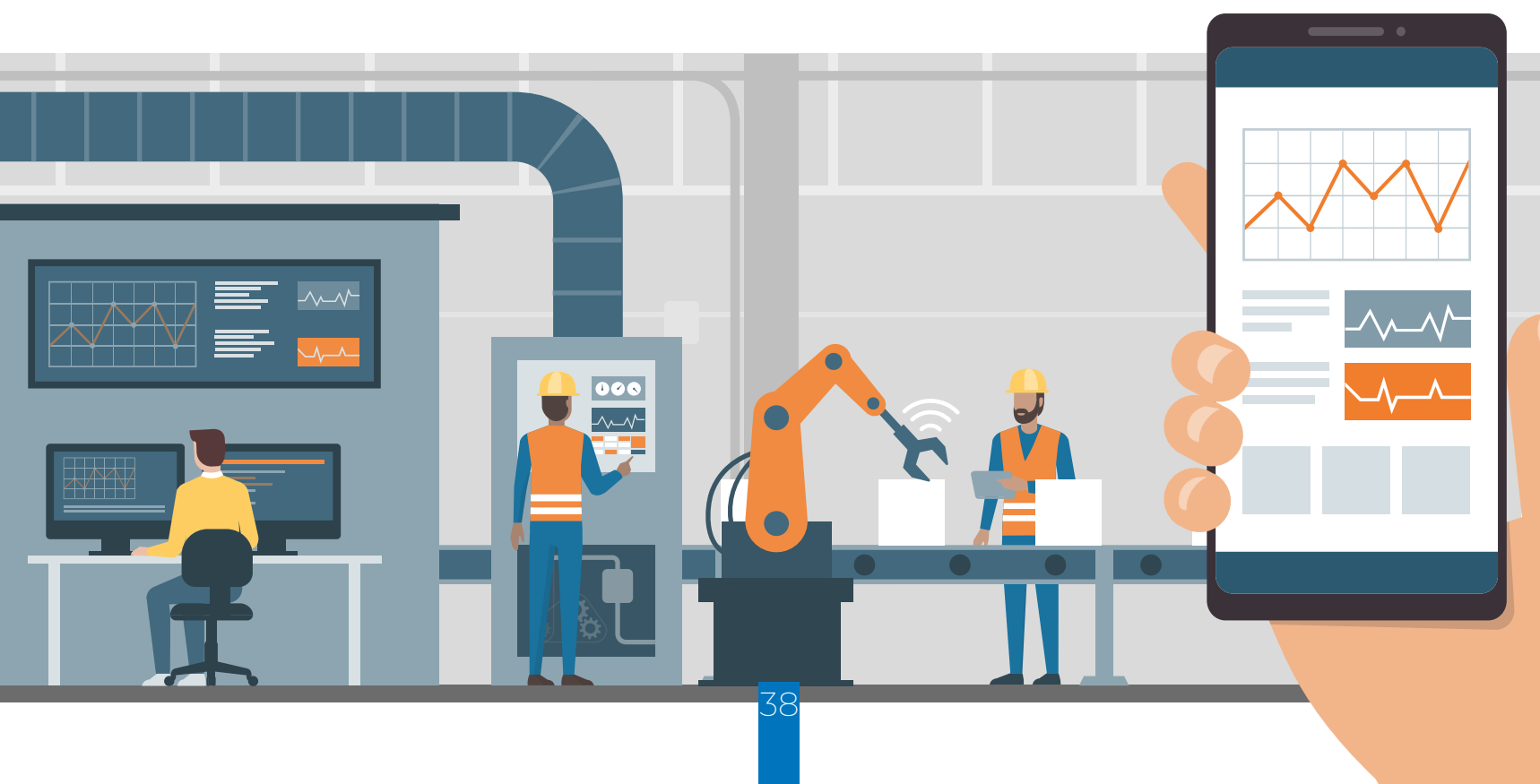

## OEM POS AND DIGITAL MARKETING

Either you need displays for showrooms, brand zones, shelves for DIY hardware shops with branding, or individual displays, you name it – we got it. We have prepared solutions for all of this market segment and yours is just to choose what you need and we can prepare it with first delivery with complete branding and language of your country. We offer also the service of designing and printing catalogs, flyers, and promotional material under your brand so we can supply selling points with all needed materials for sales and promotion.



## PRODUCT DEVELOPMENT

We have a team of industrial and mechanical engineers who are specialized in the plastic, stainless steel, and wood industries so whatever is made in a bathroom from these materials we can make it together with our partners who are specialized in these materials. We are open to all ideas and opportunities which can arise so you can be assured that you can have a trusted partner in WEBE, the bathroom solutions specialist for your new project.

